

Index	Aenderung	Datum	Visum	Freigabe
○				
○				

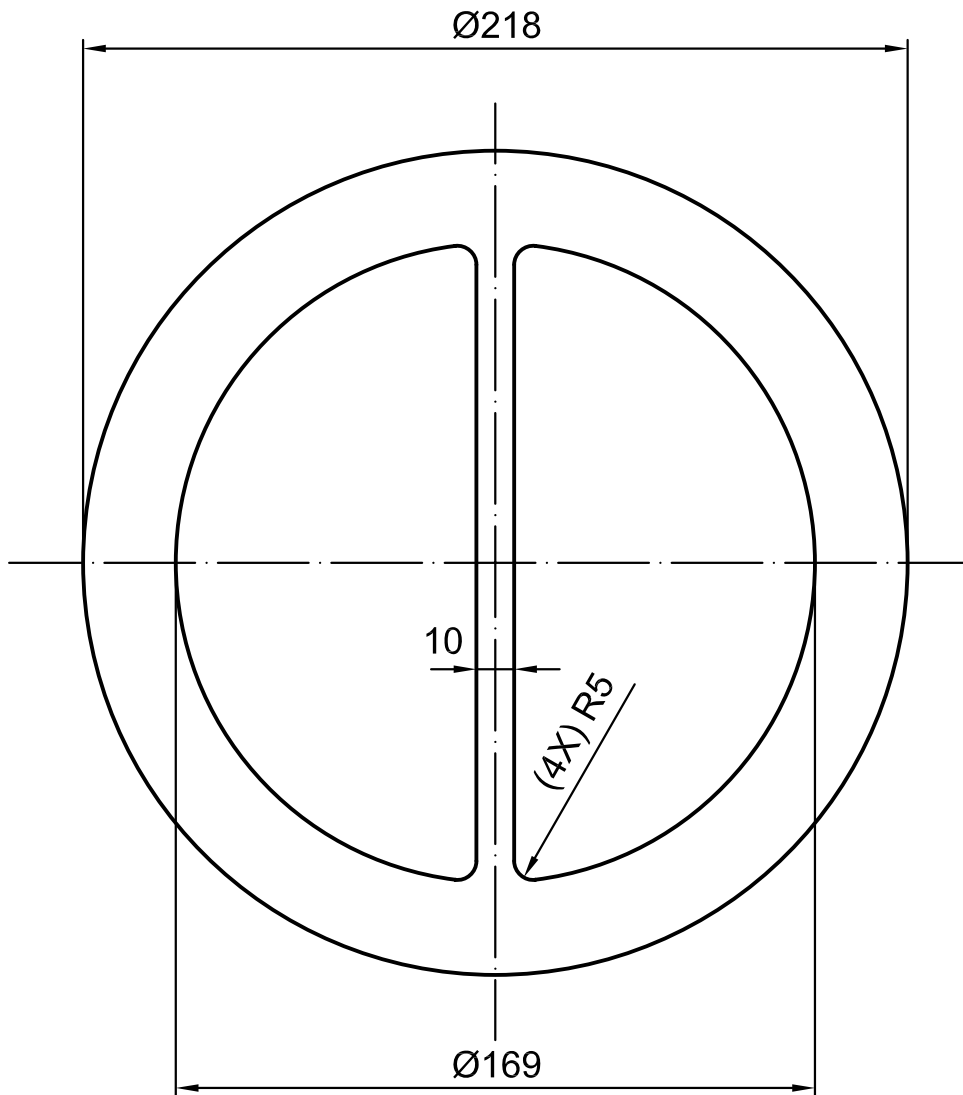

Dicke: 2 mm

1	3210-02927	Reingraphit m. Spiessblecheinlage 1401/04	Messerschnitt																																						
Pos.	Artikelnummer	Material	Bemerkung																																						
Das Urheberrecht der Zeichnung verbleibt bei Kubo Tech AG. Die Zeichnung darf ohne unser Einverständnis weder nachgebildet noch kopiert oder Dritten zugänglich gemacht werden.		Änderungen an dieser Zeichnung dürfen nur im CAD- Programm erfolgen.	Masstab 1:2																																						
Flachdichtung Ø 169 x Ø 218 x 2 mm		Massabweichungen für Stanzteile ähnlich DIN 7715 / 5 Klasse P2																																							
		<table border="1"> <thead> <tr> <th>Nennmasse über</th> <th>bis</th> <th>Längen Toleranz +/- [mm</th> <th>Dicken Toleranz +/- [mm</th> </tr> </thead> <tbody> <tr> <td>0</td> <td>6.4</td> <td>0.50</td> <td></td> </tr> <tr> <td>6.4</td> <td>25</td> <td>0.60</td> <td></td> </tr> <tr> <td>25</td> <td>40</td> <td>0.80</td> <td></td> </tr> <tr> <td>40</td> <td>63</td> <td>1.00</td> <td></td> </tr> <tr> <td>63</td> <td>100</td> <td>1.20</td> <td></td> </tr> <tr> <td>100</td> <td>160</td> <td>1.40</td> <td></td> </tr> <tr> <td>160</td> <td>250</td> <td>1.60</td> <td></td> </tr> <tr> <td>250</td> <td>400</td> <td>2.50</td> <td></td> </tr> <tr> <td>>400</td> <td></td> <td>0.8 %</td> <td></td> </tr> </tbody> </table>	Nennmasse über	bis	Längen Toleranz +/- [mm	Dicken Toleranz +/- [mm	0	6.4	0.50		6.4	25	0.60		25	40	0.80		40	63	1.00		63	100	1.20		100	160	1.40		160	250	1.60		250	400	2.50		>400		0.8 %
Nennmasse über	bis	Längen Toleranz +/- [mm	Dicken Toleranz +/- [mm																																						
0	6.4	0.50																																							
6.4	25	0.60																																							
25	40	0.80																																							
40	63	1.00																																							
63	100	1.20																																							
100	160	1.40																																							
160	250	1.60																																							
250	400	2.50																																							
>400		0.8 %																																							
		Fehlerklassifizierung für Gummiformteile und -profile nach Kubo Tech Norm 5000, Entwurf April 1996																																							
		Ersatz durch																																							
		Ersatz für																																							
		Gezeichnet	29.01.10 ABA																																						
		Geprüft	29.01.10 IBO																																						
		Konform																																							
		Freigabe																																							
KUBO		Kubo Tech AG Im Langhag 5 CH-8307 Effretikon	Tel.: 052-354 18 18 Fax.: 052-354 18 88 E-Mail: info@kubo.ch																																						
		33156	A4																																						