

Index	Aenderung	Datum	Visum	Freigabe

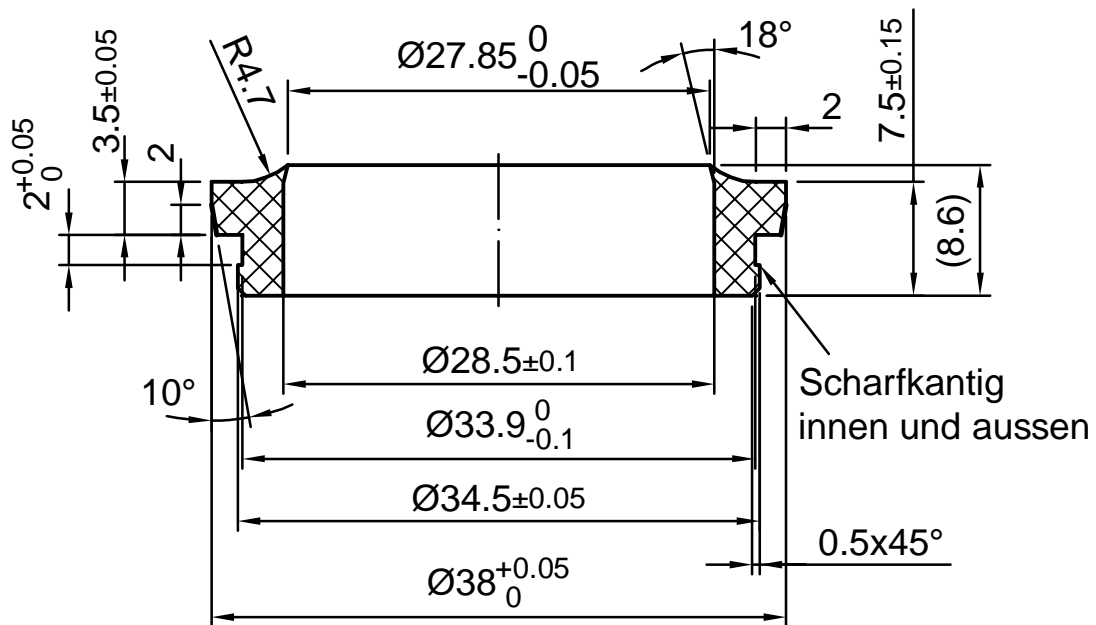

1	0340-024370	PTFE 100 (rein)	gedreht																														
Pos.	Artikelnummer	Material	Bemerkung																														
Das Urheberrecht der Zeichnung verbleibt bei Kubo Tech AG. Die Zeichnung darf ohne unser Einverständnis weder nachgebildet noch kopiert oder Dritten zugänglich gemacht werden.		Änderungen an dieser Zeichnung dürfen nur im CAD- Programm erfolgen.	Fehlerklassifizierung für Gummiformteile und -profile nach Kubo Tech Norm 5000, Entwurf April 1996																														
		Massstab 2:1	Massabweichungen für spanende Bearbeitung Kunststoff-Teile																														
			<table border="1"> <thead> <tr> <th rowspan="2">Nennmassbereich über bis</th> <th rowspan="2">Längen mittel +/-</th> <th colspan="2">Radien mittel +/-</th> </tr> <tr> <th colspan="2">Toleranzen in [mm]</th> </tr> </thead> <tbody> <tr> <td>0.5*) 3</td> <td>0.35</td> <td>0.20</td> <td></td> </tr> <tr> <td>3 6</td> <td>0.40</td> <td>0.20</td> <td></td> </tr> <tr> <td>6 30</td> <td>0.50</td> <td>0.25</td> <td></td> </tr> <tr> <td>30 120</td> <td>0.70</td> <td>0.35</td> <td></td> </tr> <tr> <td>120 400</td> <td>0.80</td> <td>0.40</td> <td></td> </tr> <tr> <td>400 1000</td> <td>1.00</td> <td>0.50</td> <td></td> </tr> </tbody> </table>	Nennmassbereich über bis	Längen mittel +/-	Radien mittel +/-		Toleranzen in [mm]		0.5*) 3	0.35	0.20		3 6	0.40	0.20		6 30	0.50	0.25		30 120	0.70	0.35		120 400	0.80	0.40		400 1000	1.00	0.50	
Nennmassbereich über bis	Längen mittel +/-	Radien mittel +/-																															
		Toleranzen in [mm]																															
0.5*) 3	0.35	0.20																															
3 6	0.40	0.20																															
6 30	0.50	0.25																															
30 120	0.70	0.35																															
120 400	0.80	0.40																															
400 1000	1.00	0.50																															
			Ersatz durch																														
			Ersatz für 0347-00220																														
			Gezeichnet 20.07.05 dl																														
			Geprüft 20.07.05 Ba																														
			Konform																														
			Freigabe																														
Abstreifer Ø 27.85 x 38 x 8.6 mm		KUBO Kubo Tech AG Im Langhag 5 CH-8307 Effretikon	Tel.: 052-354 18 18 Fax.: 052-354 18 88 E-Mail: info@kubo.ch																														
		10636	A4																														